

STRESS INTENSITY FACTOR FOR CERAMICS TOUGHENED BY MICROCRACKING CAUSED BY DILATANT SECOND PHASE PARTICLES

KAI DUAN, BRIAN COTTERELL and YIU-WING MAI

Centre for Advanced Materials Technology, Department of Mechanical Engineering,
University of Sydney, Sydney, NSW 2006, Australia

(Received 6 July 1990; in revised form 8 March 1991)

Abstract—Toughening of many ceramics can be accomplished by creating dilatation in the second phase particles that cause the matrix to crack. In this paper the stress intensity factors for annular cracks about dilatant particles in a matrix under a normal stress are calculated.

1. INTRODUCTION

Ceramics can be toughened by second phase particles that produce a residual stress system either during cooling as a result of differences in the coefficient of thermal expansion (Evans and Cannon, 1986; Porter *et al.*, 1979; Gupta *et al.*, 1978; Rühle *et al.*, 1986, 1987; Davidge, 1974; Davidge and Green, 1968; Lange, 1974; Mujata *et al.*, 1983; Mecholsky, 1983) or due to a stress-induced phase transformation. In both cases the residual stresses may lead to microcracking depending upon the particle size (Claussen, 1976; Claussen *et al.*, 1977; Rühle *et al.*, 1986, 1987; Davidge and Green, 1968; Davidge, 1974; Lange, 1974; Mujata *et al.*, 1983; Mecholsky, 1983).

If the second phase particle shrinks away from the matrix tensile, radial stresses can deflect the fracture path and cause toughening (Evans and Cannon, 1986; Davidge, 1974; Davidge and Green, 1968). Circumferential microcracks will occur between the particles and matrix if the particles are bigger than a certain critical size (Davidge, 1974; Davidge and Green, 1968). These circumferential microcracks do not greatly affect the strength of the ceramic provided the particles are not too large. This method of toughening is of importance in many ceramics of commercial significance such as electrical porcelain containing quartz filler particles.

However, this paper is aimed at ceramics where second phase particles increase in size relative to the matrix and cause radial microcracks (Evans and Cannon, 1986; Porter *et al.*, 1979; Gupta *et al.*, 1978; Claussen, 1976; Claussen *et al.*, 1977; Rühle *et al.*, 1986, 1987; Mujata *et al.*, 1983; Mecholsky, 1983). Providing the microcracks are not so large that they readily coalesce, the dilatation caused by them can produce a significant crack growth resistance (Evans and Faber, 1984). A secondary much smaller increase in toughness results from the decrease in elastic modulus in the fracture process zone due to the microcracks (Evans and Faber, 1981, 1984). The relative increase in the size of the particles can result from differences in the coefficient of thermal expansion (Mujata *et al.*, 1983; Mecholsky, 1983) or from phase transformation as in the zirconia-toughened aluminas (Claussen, 1976; Claussen *et al.*, 1977; Rühle *et al.*, 1986, 1987). The residual stress due to the volume expansion is an important factor which affects the formations of the microcracks. In the former ceramics, stress-induced microcracking occurs if the particle size is less than a critical value, or existing microcracks propagate if the residual stresses alone are sufficient to cause microcracking (Mujata *et al.*, 1983). With zirconia-toughened alumina, radial microcracking does not usually accompany the stress-induced transformation—a given particle either transforms under the stress field near the tip of a crack or if already transformed causes microcracking under the combined action of the residual and applied stresses (Rühle *et al.*, 1986).

Existing calculations of the stress intensity factors at the tips of radial cracks emanating from dilatation particles (Rühle *et al.*, 1986; Krstic and Vljajic, 1983; Krstic, 1984) assume

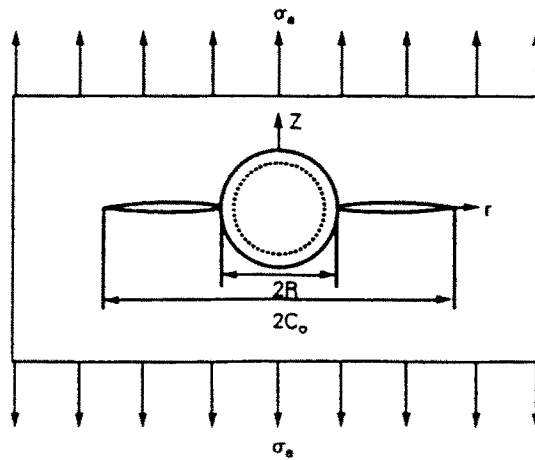

Fig. 1. "Non-particle penetrating" annular crack.

that Sneddon's classic solution (Sneddon, 1946) for the penny-shaped crack can be used. However, except under very high applied stress, the crack will not propagate far into the residual compressive stress regime of the second phase particle. A penny-shaped crack does not accurately model the behaviour of the actual annular crack. In this paper we solve the problem of an annular crack surrounding a second phase particle which undergoes a relative size increase due to thermal expansion or transformation using the triple integral equation method (Cooke, 1963; Tsai, 1984; Selvadurai and Singh, 1984, 1985, 1987; Selvadurai, 1985). At high applied stress the annular crack will propagate into the residual compressive stress regime. In some cases where the second phase material is similar to the matrix and very well bonded the annular crack will propagate into the second phase particles. An example of this type of cracking is shown by Mujata *et al.* (1983). However, in other cases where the particle is not so well bonded, any propagation into the compressive region will take place by the crack running along the particle/matrix interface (Rühle *et al.*, 1987). The present analysis only deals with the former type of crack growth where the annular crack may penetrate into the particle.

2. THE ANNULAR CRACK PROBLEM

A system consisting of a spherical particle embedded in an infinite brittle matrix and having a surrounding annular crack is considered (Fig. 1). The case where the crack extends into the particle is also considered (Fig. 2). It is assumed that the elastic constants for the particle and the matrix are identical so that the principle of superposition can be applied. There are two load systems: (a) the residual stresses due to the mismatch between the particle and matrix and (b) a uniform tensile stress σ .

The pressure P between the particle and the matrix is given by

$$P = \frac{2\varepsilon^l E}{3(1-\nu)} \quad (1)$$

where for phase transformation ε^l is the stress-free strain and for thermal expansion mismatches $\varepsilon^l = (\alpha_m - \alpha_p)\Delta T$; E is the Young's modulus; ν is Poisson's ratio; α is the coefficient of thermal expansion; and the subscripts m and p refer to the matrix and particle. In the absence of any crack the residual stress field on the plane $z = 0$ is given by

$$\sigma_z(r, 0) = -P \quad \text{for } r < R, \quad (2)$$

and

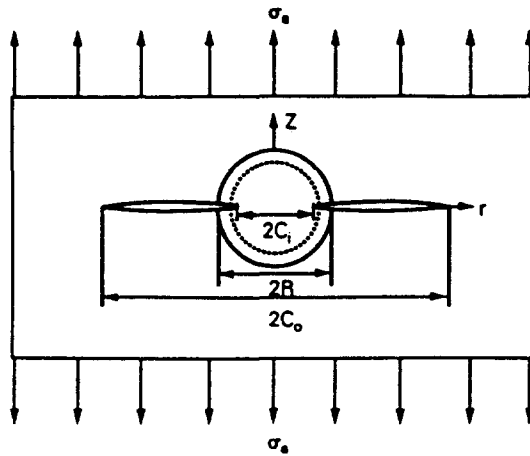

Fig. 2. "particle penetrating" annular crack.

$$\sigma_z(r, 0) = \frac{P}{2} \left(\frac{R}{r} \right)^3 \quad \text{for } r > R, \tag{3}$$

where R is the radius of the particle. In the presence of an annular crack this residual stress field is superimposed by the stress field

$$\sigma_z(r, 0) = P \quad \text{for } c_1 < r < R, \tag{4}$$

$$\sigma_z(r, 0) = -\frac{P}{2} \left(\frac{R}{r} \right)^3 \quad \text{for } c_0 > r > R, \tag{5}$$

where c_1 and c_0 are the radii of the inner and outer edges of the annular crack, there are also the added conditions that on the plane $z = 0$ the displacement u_z is zero outside the crack and the shear stress is zero.

The stress field due to an applied uniform stress σ superimposed on the crack system is

$$\sigma_z = -\sigma \quad \text{for } c_1 < r < c_0, \tag{6}$$

with the conditions that in the plane $z = 0$, u_z is zero outside the crack and the shear stress is zero. The solution to this problem of the annular crack under uniform stress has already been given by Selvadurai and Singh (1985), but only for $c_1/c_0 < 0.7$.

The stress intensity factors K_1 and K_0 at the inner and outer edges of the annular crack are given by

$$K_1 = \lim_{r \rightarrow c_1^+} \sigma_z(r, 0) \sqrt{2\pi(c_1 - r)}, \tag{7}$$

$$K_0 = \lim_{r \rightarrow c_0^-} \sigma_z(r, 0) \sqrt{2\pi(r - c_0)}. \tag{8}$$

3. THE SOLUTION OF THE ANNULAR CRACK PROBLEM

Hankel transforms can be used in axisymmetric problems to reduce the two independent variables (r, z) to a single variable z (Harding and Sneddon, 1945; Sneddon 1946,

1951; Sneddon and Lowengrub, 1969). The biharmonic equation for the stress function ϕ then becomes

$$\left[\frac{d^2}{dz^2} - \zeta^2 \right]^2 G = 0, \quad (9)$$

where

$$G = \int_0^x r\phi(r)J_0(\zeta r) dr, \quad (10)$$

$J_0(\zeta r)$ is a Bessel function of zero order and ζ is a parameter. On the plane $z = 0$, the longitudinal stress and displacement can be written as

$$\sigma_z(\rho, 0) = \frac{E}{(1+\nu)(1-2\nu)c_0^4} \int_0^x \eta f(\eta) J_0(\rho\eta) d\eta, \quad (11)$$

$$u_z(\rho, 0) = -\frac{2(1-\nu)}{(1-2\nu)c_0^3} \int_0^x f(\eta) J_0(\rho\eta) d\eta, \quad (12)$$

where $\rho = r/c_0$ and $\zeta = \eta/c_0$,

$$f(\eta) = \eta^2 B\left(\frac{\eta}{c_0}\right). \quad (13)$$

Inserting the boundary conditions given in Section 2 into eqns (11) and (12), we obtain the following triple integral equations,

$$\int_0^{\alpha} f(\eta) J_0(\rho\eta) d\eta = 0 \quad (0 < \rho < \alpha), \quad (14)$$

$$\int_0^{\alpha} \eta f(\eta) J_0(\rho\eta) d\eta = g(\rho) \quad (\alpha < \rho < 1), \quad (15)$$

$$\int_0^{\infty} f(\eta) J_0(\rho\eta) d\eta = 0 \quad (1 < \rho < \infty), \quad (16)$$

where

$$g(\rho) = \frac{(1+\nu)(1-2\nu)c_0^4}{E} \sigma_z(\rho, 0) \quad \alpha < \rho < 1, \quad (17)$$

and $\sigma_z(\rho, 0)$ is given by eqns (4) and (5) for the residual stress and eqn (6) for the applied stress and where $\alpha = c_1/c_0$.

Let

$$g_1(\rho) = g(\rho) \quad (0 < \rho < \alpha), \quad (18)$$

and

$$g_2(\rho) = g(\rho) \quad (1 < \rho < \infty). \quad (19)$$

Then, we have,

$$K_I = \lim_{\rho \rightarrow \alpha^-} \frac{g_1(\rho)}{C} \sqrt{2c_0\pi(\alpha - \rho)}, \quad (20)$$

and

$$K_O = \lim_{\rho \rightarrow 1^+} \frac{g_2(\rho)}{C} \sqrt{2c_0\pi(\rho - 1)}, \quad (21)$$

where

$$C = \frac{(1+\nu)(1-2\nu)c_0^4}{E}. \quad (22)$$

It is seen that one only needs to find $g_1(\rho)$ and $g_2(\rho)$ in order to determine the stress intensity factors. We make a note that

$$G_1(s) = \int_s^\alpha \frac{ug_1(u)}{(u^2 - s^2)^{1/2}} du \quad (0 \leq s < \alpha), \quad (23)$$

and

$$G_2(s) = \int_1^s \frac{ug_2(u)}{(s^2 - u^2)^{1/2}} du \quad (1 < s < \infty). \quad (24)$$

Then the triple integral eqns (14–16) can be simplified as a pair of simultaneous integral equations for $g_1(u)$ and $g_2(u)$ that is written as (Cooke, 1963; Tsai, 1984; Selvadurai and Singh, 1984, 1985, 1987; Selvadurai, 1985).

$$\int_0^\rho \left[G_1(s) + \int_s^1 \frac{ug(u) du}{(u^2 - s^2)^{1/2}} \right] \frac{ds}{(\rho^2 - s^2)^{1/2}} = - \int_1^\infty \frac{G_2(s) ds}{(s^2 - \rho^2)^{1/2}} \quad (0 < \rho < \alpha), \quad (25)$$

$$\int_1^\infty \left[G_2(s) + \int_s^1 \frac{ug(u) du}{(s^2 - u^2)^{1/2}} \right] \frac{ds}{(s^2 - \rho^2)^{1/2}} = - \int_0^\alpha \frac{G_1(s) ds}{(\rho^2 - s^2)^{1/2}} \quad (1 < \rho < \infty). \quad (26)$$

Let $G_{11}(s)$ and $G_{21}(s)$, $G_{12}(s)$ and $G_{22}(s)$ satisfy the following simultaneous integral equations:

$$\int_0^\rho \left[G_{11}(s) + \int_s^1 \frac{u\sigma du}{(u^2 - s^2)^{1/2}} \right] \frac{ds}{(\rho^2 - s^2)^{1/2}} = - \int_1^\infty \frac{G_{21}(s) ds}{(s^2 - \rho^2)^{1/2}} \quad (0 < \rho < \alpha), \quad (27)$$

$$\int_1^\infty \left[G_{21}(s) + \int_s^1 \frac{u\sigma du}{(s^2 - u^2)^{1/2}} \right] \frac{ds}{(s^2 - \rho^2)^{1/2}} = - \int_0^\alpha \frac{G_{11}(s) ds}{(\rho^2 - s^2)^{1/2}} \quad (1 < \rho < \infty), \quad (28)$$

$$\int_0^\rho \left[G_{12}(s) + \int_s^1 \frac{ug(u) du}{(u^2 - s^2)^{1/2}} \right] \frac{ds}{(\rho^2 - s^2)^{1/2}} = - \int_1^\infty \frac{G_{22}(s) ds}{(s^2 - \rho^2)^{1/2}} \quad (0 < \rho < \alpha), \quad (29)$$

$$\int_1^\infty \left[G_{22}(s) + \int_s^1 \frac{ug(u) du}{(s^2 - u^2)^{1/2}} \right] \frac{ds}{(s^2 - \rho^2)^{1/2}} = - \int_0^\alpha \frac{G_{12}(s) ds}{(\rho^2 - s^2)^{1/2}} \quad (1 < \rho < \infty). \quad (30)$$

Then

$$G_1(s) = \frac{(1+\nu)(1-2\nu)c_0^3}{E} [G_{11}(s) + G_{12}(s)] \quad (0 < s < \alpha), \quad (31)$$

$$G_2(s) = \frac{(1+\nu)(1-2\nu)c_0^4}{E} [G_{21}(s) + G_{22}(s)] \quad (1 < s < \infty), \quad (32)$$

gives the solution of integral eqns (25) and (26). Function $g(u)$ is written as

$$g(u) = -\frac{CP\beta^3}{2u^3} \quad (\beta < u < 1), \quad (33)$$

for the case when the crack does not penetrate into the particle and

$$g(u) = \begin{cases} CP & (\alpha < u < \beta) \\ -\frac{CP\beta^3}{2u^3} & (\beta < u < 1) \end{cases}, \quad (34)$$

if the crack penetrates into the particle, where $\beta = R/c_0$.

In order to get the approximate solutions of eqns (27-30), we use a perturbation method and express the solutions in series form.

$$G_{11}(s) = \sigma \sum_{n=1}^{\infty} \alpha^n A_{1n} \left(\frac{s}{\alpha} \right) \quad (0 < s < \alpha), \quad (35)$$

$$G_{21}(s) = \sigma \sum_{n=1}^{\infty} \alpha^n B_{1n}(s) \quad (1 < s < \infty), \quad (36)$$

$$G_{12}(s) = \frac{P\alpha}{2} \sum_{n=1}^{\infty} \alpha^n A_{2n} \left(\frac{s}{\alpha} \right) \quad (0 < s < \alpha), \quad (37)$$

$$G_{22}(s) = \frac{P\alpha}{2} \sum_{n=1}^{\infty} \alpha^n B_{2n}(s) \quad (1 < s < \infty). \quad (38)$$

From Abel's integral equation (Cooke, 1963; Selvadurai and Singh, 1985), we have,

$$g_1(\rho) = \frac{2C}{\pi\rho} \frac{d}{d\rho} \int_{\rho}^{\alpha} \frac{s[G_{11}(s) + G_{12}(s)]}{(s^2 - \rho^2)^{1/2}} ds \quad (0 < \rho < \alpha), \quad (39)$$

$$g_2(\rho) = -\frac{2C}{\pi\rho} \frac{d}{d\rho} \int_1^{\rho} \frac{s[G_{21}(s) + G_{22}(s)]}{(\rho^2 - s^2)^{1/2}} ds \quad (1 < \rho). \quad (40)$$

The stress intensity factors for the residual stress system K_1^r , K_2^r and those for the applied stress K_1^a , K_2^a can be obtained from eqns (20-21) as a series.

4. THE STRESS INTENSITY FACTORS FOR ANNULAR CRACKS SURROUNDING DILATATION PARTICLES

The non-dimensional stress intensity factors at the inner and outer edges of an annular crack under the influence of the residual stresses around a mismatched particle ($k^p = K^p/P\sqrt{\pi c_0}$) are given in Table 1 and are shown in Figs 3 and 4. To achieve sufficient

Table 1. The non-dimensional stress intensity factors due to a dilatant particle (a) K_I^* at the inner edge, (b) K_{II}^* at the outer edge of the crack

I(a)		β										
x/β		0.020	0.050	0.100	0.250	0.333	0.500	0.556	0.625	0.714	0.833	1.0
0.1	-0.212	-0.336	-0.476	-0.756	-0.874	-1.066	-1.120	-1.181	-1.247	-1.310	-1.323	
0.2	-0.147	-0.232	-0.330	-0.528	-0.612	-0.753	-0.793	-0.838	-0.888	-0.937	-0.950	
0.3	-0.115	-0.183	-0.260	-0.418	-0.487	-0.604	-0.638	-0.676	-0.719	-0.763	-0.775	
0.4	-0.094	-0.149	-0.212	-0.345	-0.403	-0.504	-0.534	-0.569	-0.608	-0.648	-0.660	
0.5	-0.077	-0.122	-0.174	-0.286	-0.336	-0.425	-0.452	-0.483	-0.520	-0.558	-0.569	
0.6	-0.061	-0.098	-0.140	-0.232	-0.275	-0.353	-0.377	-0.406	-0.441	-0.478	-0.488	
0.7	-0.046	-0.074	-0.106	-0.179	-0.215	-0.282	-0.303	-0.330	-0.362	-0.399	-0.410	
0.8	-0.029	-0.047	-0.069	-0.121	-0.148	-0.202	-0.221	-0.244	-0.275	-0.313	-0.327	
0.9	-0.009	-0.015	-0.023	-0.048	-0.064	-0.101	-0.115	-0.134	-0.161	-0.200	-0.227	
1.0	0.045	0.070	0.096	0.141	0.155	0.167	0.167	0.164	0.155	0.129	0.000	

I(b)		β										
x/β		0.050	0.100	0.250	0.333	0.500	0.556	0.625	0.714	0.833	1.0	
0.1	0.000	0.000	0.001	0.001	0.000	-0.009	-0.016	-0.031	-0.062	-0.142	-0.610	
0.2	0.000	0.001	0.003	0.004	0.004	0.000	-0.006	-0.018	-0.046	-0.121	-0.580	
0.3	0.000	0.001	0.005	0.007	0.007	0.007	0.004	-0.006	-0.029	-0.098	-0.548	
0.4	0.000	0.001	0.007	0.011	0.011	0.015	0.014	0.008	-0.011	-0.073	-0.513	
0.5	0.000	0.001	0.008	0.014	0.014	0.023	0.024	0.021	0.007	-0.046	-0.473	
0.6	0.000	0.002	0.010	0.017	0.017	0.031	0.034	0.035	0.026	-0.017	-0.427	
0.7	0.000	0.002	0.012	0.020	0.020	0.039	0.044	0.048	0.046	0.013	-0.374	
0.8	0.001	0.002	0.013	0.022	0.022	0.045	0.053	0.060	0.064	0.046	-0.309	
0.9	0.001	0.002	0.014	0.024	0.024	0.050	0.059	0.070	0.081	0.078	-0.221	
1.0	0.001	0.002	0.013	0.023	0.023	0.050	0.060	0.072	0.086	0.094	0.020	

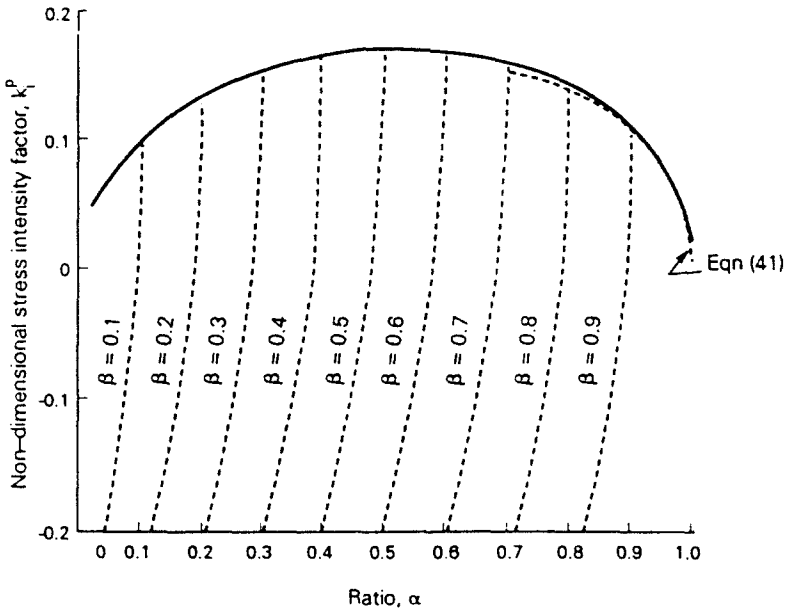

Fig. 3. Non-dimensional stress intensity factor at the inner edge of an annular crack at a dilatant particle, applied stress $\sigma = 0$ (— $\alpha = \beta$, - - - constant β).

accuracy for the stress intensity factors for $\alpha < 0.6$ it is only necessary to retain about five terms in the series expansions for eqns (35–38). However, as $\alpha \rightarrow 1$ it is necessary to take up to a hundred terms to ensure an accurate result (for $\alpha < 0.95$ the accuracy is better than 0.25%). There is a limiting solution for α close to unity since in this case the problem is identical to a two-dimensional crack of length $(c_o - c_i)$ under a state of plane strain. Hence, the limiting condition can be obtained by integration of the expression for the stress intensity factor for a two-dimensional crack with point loads on the crack faces (Paris and Sih, 1965)

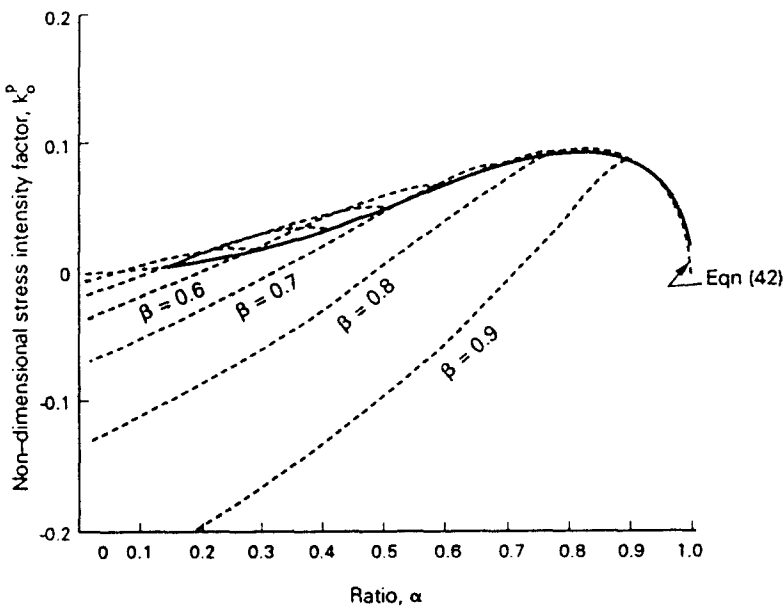

Fig. 4. Non-dimensional stress intensity factor at the outer edge of an annular crack at a dilatant particle, applied stress $\sigma = 0$ (— $\alpha = \beta$, - - - constant β).

and is given by

$$K_i^p = \sqrt{\frac{2}{\pi(c_o - c_i)}} \int_{c_i}^{c_o} \sigma_z(r, 0) \sqrt{\frac{r - c_i}{c_o - r}} dr, \quad (41)$$

$$K_o^p = \sqrt{\frac{2}{\pi(c_o - c_i)}} \int_{c_i}^{c_o} \sigma_z(r, 0) \sqrt{\frac{c_o - r}{r - c_i}} dr. \quad (42)$$

The non-dimensional forms of these limiting solutions are shown in Figs 3 and 4. The stress intensity factors are given by the empirical expressions

$$k_i^p = 0.334\beta^{0.520}(1 - \beta)^{0.479}, \quad (43)$$

$$k_o^p = 0.335\beta^{2.25}(1 - \beta)^{0.483}, \quad (44)$$

which are accurate to 0.25% over the entire range $\beta = 0-1$.

The stress intensity factors for an annular crack under a uniform tensile stress have already been given by Selvadurai and Singh (1985) for α up to 0.7. In their solution they take only five terms in the expression for eqns (42-45). We have extended the range up to $\alpha = 1$ which again requires up to a hundred terms in eqns (42-45). The results for the non-dimensional stress intensity factors ($k^\sigma = K/\sigma\sqrt{\pi c_o}$) are given in Table 2 and Fig. 5. Once again a limiting solution can be obtained for α close to unity and is given by

$$k_i^\sigma = k_o^\sigma = (1 - \alpha)^{1/2}/\sqrt{2}. \quad (45)$$

These stress intensity factors are given by the empirical expressions

$$k_i^\sigma = 0.458 \frac{(1 - \alpha^2)^{0.431}}{\alpha^{0.469}}, \quad (46)$$

$$k_o^\sigma = 0.644(1 - \alpha)^{0.456}, \quad (47)$$

which again are accurate to 0.25% over the entire range $\alpha = 0-1$.

Figure 5 also shows the non-dimensional stress intensity factor obtained by superposition for a dilatant particle with uniform stress applied. The effect of a crack penetrating the dilatant particle is shown in Fig. 6 for $P/\sigma = 2$.

Table 2. The non-dimensional stress intensity factors at the inner (k_i^σ) and outer edge (k_o^σ) of the crack

α	k_i^σ	k_o^σ
1.0	0.0395	0.0388
0.833	0.2963	0.2830
0.714	0.3984	0.3657
0.625	0.4685	0.4149
0.556	0.5231	0.4484
0.500	0.5686	0.4729
0.333	0.7324	0.5369
0.250	0.8510	0.5648
0.200	0.9499	0.5804
0.100	1.3230	0.6097
0.050	1.8455	0.6235
0.020	2.8881	0.6314

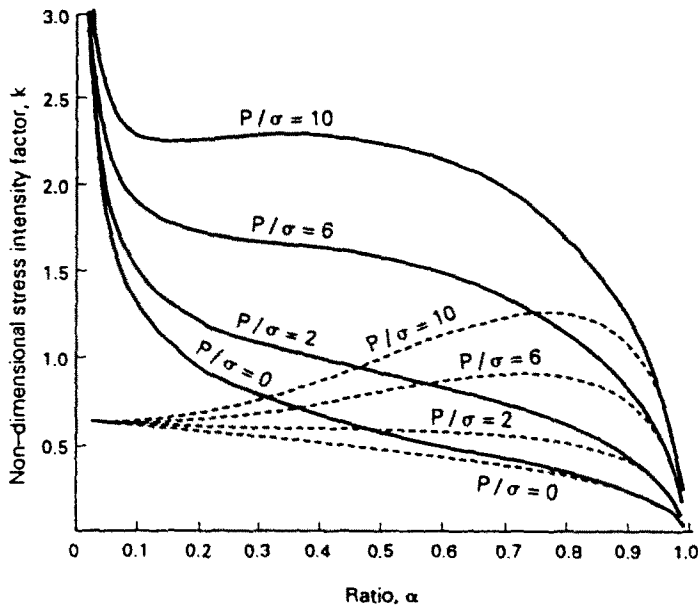

Fig. 5. Non-dimensional stress intensity factor at the inner (—) and outer (---) edges of an annular crack that does not penetrate the dilatant particle for a range of applied stresses.

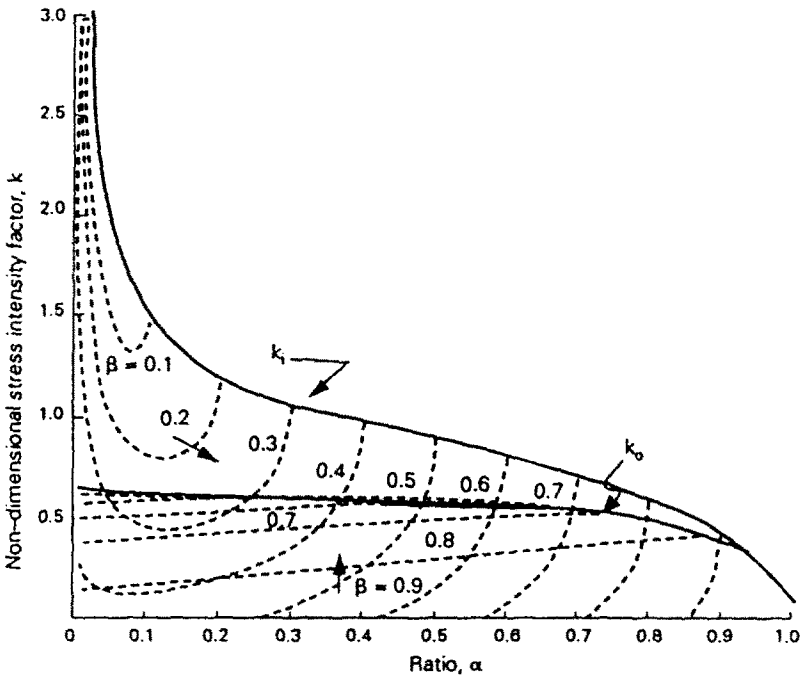

Fig. 6. Non-dimensional stress intensity factor at the inner and outer edges of an annular crack for $P/\sigma = 2$ (— $\alpha = \beta$, --- constant β).

5. CONCLUSIONS

The stress intensity factors for annular cracks around dilatant particles have been obtained by use of Hankel transforms after the method of Selvadurai and Singh (1985) for the complete range of inner to outer radii. These stress intensity factors are accurate to 0.25%. Previous calculations of the stress intensity (Rühle *et al.*, 1987; Krstic *et al.*, 1983; Krstic, 1984) made using Sneddon's (1946) classic solution for a penny-shaped crack are only approximately correct if the annular crack is very large compared with the dilatant particle—for small annular cracks the stress intensity factors are grossly overestimated.

The stress intensity factor at the inner edge of an annular crack formed outside a dilatant particle is always greater than that at the outer edge. Thus there is a strong tendency for a crack to penetrate the dilatant particle, if the particle is well bonded to the matrix. However, if there is no applied stress, the stress intensity factor decreases rapidly as the crack penetrates the compressive stress zone in the dilatant particle (Fig. 3). If the compressive stress due to the dilatant particle is greater than the applied stress, initial crack propagation into the dilatant particle is always stable. Crack propagation into the particle becomes unstable only when the penetration is large.

Acknowledgements—The authors wish to thank the Australian Research Council for the support of this work which is part of a larger project on "Structural Reliability of Tough Zirconia Ceramics". One of us (D.K.) is supported by the CSIRO Sydney University Research Scholarship.

REFERENCES

- Claussen, N. (1976). Fracture toughness of Al_2O_3 with an unstabilised ZrO_2 dispersed phase. *J. Am. Ceram. Soc.* **59**, 49–51.
- Claussen, N., Steeb, J. and Pabst, R. F. (1977). Effect of induced microcracking on the fracture toughness of ceramics. *Am. Ceram. Soc. Bull.* **56**, 559–562.
- Cooke, J. C. (1963). Triple integral equations. *Quart. J. Mech. Appl. Math.* **16**, 193–203.
- Davidge, R. W. (1974). Effects of microstructure on the mechanical properties of ceramics. In *Fracture Mechanics of Ceramics 2* (Edited by R. C. Bradt, D. P. H. Hasselman and F. F. Lange), pp. 447–468. Plenum Press, New York.
- Davidge, R. W. and Green, T. J. (1968). The strength of two-phase ceramics/glass materials. *J. Mater. Sci.* **3**, 629–634.
- Evans, A. G. and Cannon, R. M. (1986). Overview No. 48, toughening of brittle solids by martensitic transformations. *Acta Metall.* **34**, 761–800.
- Evans, A. G. and Faber, K. T. (1981). Toughening of ceramics by circumferential microcracking. *J. Am. Ceram. Soc.* **64**, 394–398.
- Evans, A. G. and Faber, K. T. (1984). Crack-growth resistance of microcracking brittle materials. *J. Am. Ceram. Soc.* **67**, 255–260.
- Gupta, T. K., Lange, F. F. and Bechtold, J. H. (1978). Effect of stress-induced phase transformations on the properties of polycrystalline zirconia containing metastable tetragonal phase. *J. Mater. Sci.* **13**, 1464–1470.
- Harding, J. W. and Sneddon, I. N. (1945). The elastic stresses produced by the indentations of the plane surface of a semi-infinite elastic solid by a rigid punch. *Proc. Camb. Phil. Soc.* **41**, 16–26.
- Krstic, V. D. (1984). Fracture of brittle solids in the presence of thermoelastic stresses. *J. Am. Ceram. Soc.* **67**, 589–593.
- Krstic, V. D. and Vljacic, M. D. (1983). Conditions for spontaneous cracking of a brittle matrix due to the presence of thermoelastic stresses. *Acta Metall.* **31**, 139–144.
- Lange, F. F. (1974). Criteria for crack extension and arrest in residual, localized stress fields associated with second phase particles. In *Fracture Mechanics of Ceramics 2* (Edited by R. C. Bradt, D. P. H. Hasselman and F. F. Lange), pp. 559–609. Plenum Press, New York.
- Mecholsky, J. J. (1983). Toughening in glass ceramics through microstructural design. In *Fracture Mechanics of Ceramics 6* (Edited by R. C. Bradt, A. G. Evans, D. P. H. Hasselman and F. F. Lange), pp. 165–180. Plenum Press, New York.
- Mujata, N., Langgawa, K. and Ginno, H. (1983). Fracture behavior of glass matrix/glass particle composites. In *Fracture Mechanics of Ceramics 5* (Edited by R. G. Bradt, A. G. Evans, D. P. H. Hasselman and F. F. Lange), pp. 609–634. Plenum Press, New York.
- Paris, P. C. and Sih, A. G. (1965). Stress analysis of cracks. In *Fracture Roughness Testing and Applications*, ASTM STP 381, 30–82. Philadelphia.
- Porter, D. L., Evans, A. G. and Heuer, H. H. (1979). Transformations toughening in partially stabilized zirconia (PSZ). *Acta Metall.* **27**, 1649–1654.
- Rühle, M., Claussen, N. and Heuer, A. H. (1986). Transformations and microcracking toughening as complementary process in ZrO_2 -toughened Al_2O_3 . *J. Am. Ceram. Soc.* **69**, 195–197.
- Rühle, M., Evans, A. G., McMeeking, R. M., Charalamides, P. G. and Hutchinson, J. W. (1987). Microcrack toughening in alumina/zirconia. *Acta Metall.* **35**, 2701–2710.
- Selvadurai, A. P. S. (1985). On integral equations governing an internally indented penny-shaped crack. *Mech. Res. Com.* **12**, 347–351.
- Selvadurai, A. P. S. and Singh, B. M. (1984). On the expansion of a penny-shaped crack by a rigid circular disc inclusion. *Int. J. Frac.* **25**, 59–77.
- Selvadurai, A. P. S. and Singh, B. M. (1985). The annular crack problem for an isotropic elastic solid. *Quart. J. Mech. Appl. Math.* **38**, 233–243.
- Selvadurai, A. P. S. and Singh, B. M. (1987). Axisymmetric problems for an externally cracked elastic solid. I. Effect of a penny-shaped crack. *Int. J. Engng Sci.* **25**, 1049–1057.
- Sneddon, I. N. (1946). The distribution of stress in the neighbourhood of a crack in an elastic solid. *Proc. Roy. Soc. (London)* **A187**, 229–260.
- Sneddon, I. N. (1951). *Fourier Transforms*. McGraw-Hill, New York.

- Sneddon, I. N. and Lowengrub, M. (1969). *Crack Problems in the Classical Theory of Elasticity*. John Wiley, New York.
- Timoshenko, S. and Goodier, J. N. (1934). *Theory of Elasticity*. McGraw-Hill, New York.
- Tsai, Y. M. (1984). Indentation of a penny-shaped crack by an oblate spheroidal rigid inclusion in a transversely isotropic medium. *J. Appl. Mech. Trans. (ASME)* **51**, 811-815.